

NHD-5.0-800480TF-ATXL#-CTP

TFT (Thin-Film-Transistor) Color Liquid Crystal Display Module

NHD-	Newhaven Display
5.0-	5.0" Diagonal
800480-	800xRGBx480 pixels
TF-	Model
A-	Built-in driver / No Controller
T-	White LED backlight
X-	TFT
L-	12:00 Optimum View, Enhanced Optical Characteristics, Wide Temp
#	RoHS Compliant
CTP	Capacitive touch panel with controller

Newhaven Display International, Inc.

2511 Technology Drive, Suite 101

Elgin IL, 60124

Ph: 847-844-8795

Fax: 847-844-8796

www.newhavendisplay.com

nhtech@newhavendisplay.com

nhsales@newhavendisplay.com

Document Revision History

Revision	Date	Description	Changed by
0	3/20/2013	Initial Release	AK
1	8/28/2013	Electrical characteristics updated	AK

Functions and Features

- 800xRGBx480 resolution, up to 16.7M colors
- 18-LED backlight
- 24 bit RGB interface
- Enhanced Optical Characteristics
- Capacitive Touch Panel with controller

Mechanical Drawing

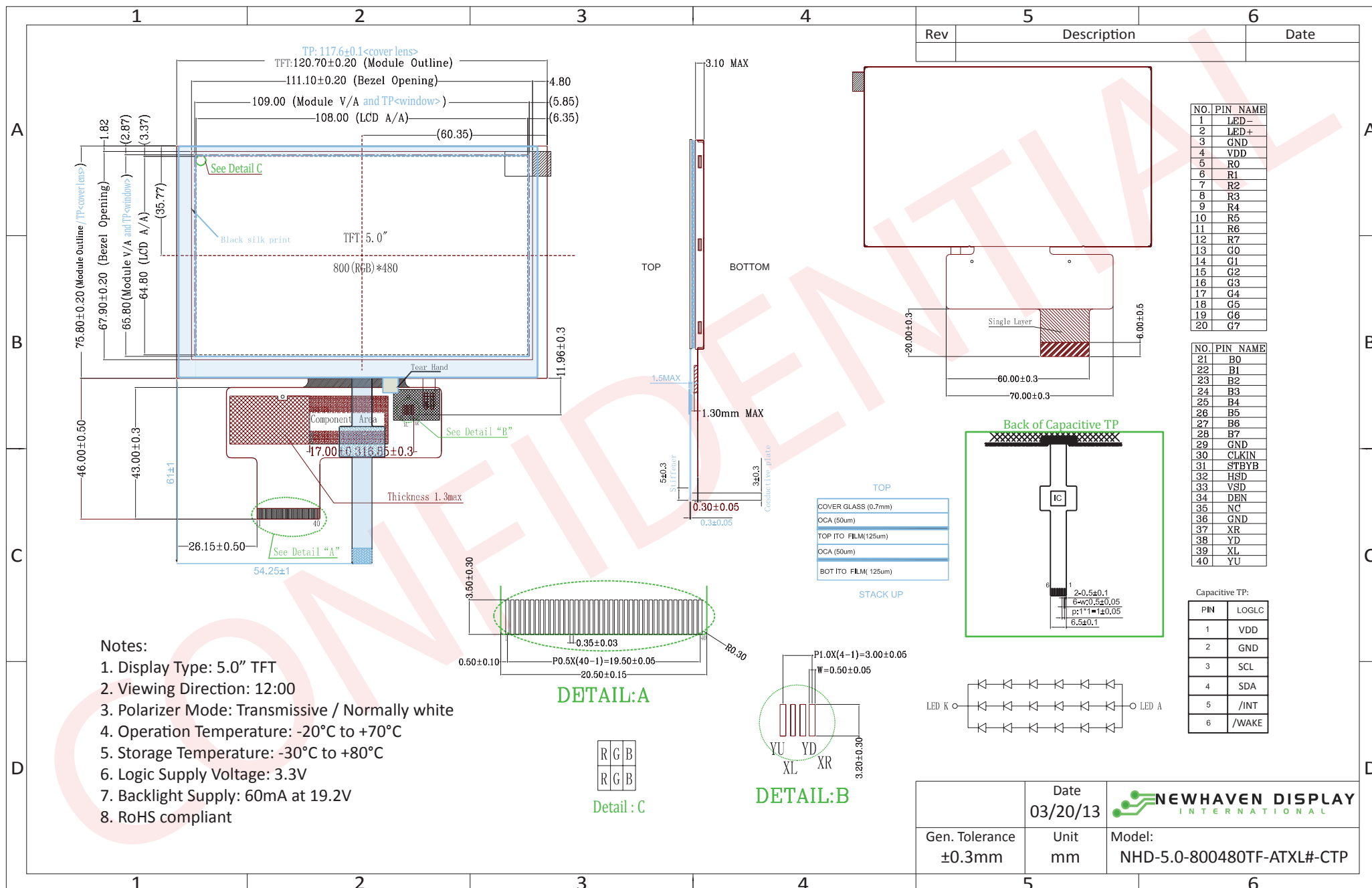

The drawing contained herein is the exclusive property of Newhaven Display International, Inc. and shall not be copied, reproduced, and/or disclosed in any format without permission.

Pin Description

TFT:

Pin No.	Symbol	External Connection	Function Description
1	LED-	LED Power Supply	Ground for Backlight
2	LED+	LED Power Supply	Backlight Power Supply (60mA @ ~19.2V)
3	GND	Power Supply	Ground
4	VDD	Power Supply	Power supply for LCD and logic (3.3V)
5-12	[R0-R7]	MPU	Red Data Signals
13-20	[G0-G7]	MPU	Green Data Signals
21-28	[B0-B7]	MPU	Blue Data Signals
29	GND	Power Supply	Ground
30	CLKIN	MPU	Clock for input data (Rising Edge)
31	STBYB	MPU	1: Normal Operation; 0: Standby Mode
32	HSD	MPU	Line synchronization signal
33	VSD	MPU	Frame synchronization signal
34	DEN	MPU	Data Enable signal
35	NC	-	No Connect
36	GND	Power Supply	Ground
37	XR	-	No Connect
38	YD	-	No Connect
39	XL	-	No Connect
40	YU	-	No Connect

Recommended LCD connector: 0.5mm pitch 40-Conductor FFC. Molex p/n: 54104-4031 (top contact)

Backlight connector: on LCD connector

Mates with: ---

Capacitive Touch Panel:

Pin No.	Symbol	External Connection	Function Description
1	VCC	Power Supply	Power supply for logic (3.0V)
2	GND	Power Supply	Ground
3	SCL	MPU	Serial I2C Clock (Requires pull-up resistor)
4	SDA	MPU	Serial I2C Data (Requires pull-up resistor)
5	/INT	MPU	Interrupt signal from touch panel module to host
6	/WAKE	MPU	External interrupt signal from host (0: Disable /INT 1: Enable /INT)

Recommended connector: 1.0mm pitch 6-Conductor FFC. Molex p/n: 52271-0679

Driver/Controller Information

TFT:

Built-in HX8264-D02 Source Driver: http://www.newhavendisplay.com/app_notes/HX8264-D02.pdf

Built in HX8664-B Gate Driver: http://www.newhavendisplay.com/app_notes/HX8664-B.pdf

Capacitive Touch Panel:

Built-in FocalTech FT5x06 controller.

Please download specification at http://www.newhavendisplay.com/app_notes/FT5x06.pdf

Electrical Characteristics

TFT:

Item	Symbol	Condition	Min.	Typ.	Max.	Unit
Operating Temperature Range	Top	Absolute Max	-20	-	+70	°C
Storage Temperature Range	Tst	Absolute Max	-30	-	+80	°C
Supply Voltage	VDD		3.0	3.3	3.6	V
Supply Current	IDD	VDD=3.3	130	164	200	mA
"H" Level input	Vih		0.7*VDD	-	VDD	V
"L" Level input	Vil		0	-	0.3*VDD	V
"H" Level output	Voh		VDD-0.4	-	-	V
"L" Level output	Vol		-	-	GND+0.4	V
Backlight Supply Voltage	VLED		16.2	19.2	20.4	V
Backlight Supply Current	ILED		45	60	75	mA

Capacitive Touch Panel:

Item	Symbol	Condition	Min.	Typ.	Max.	Unit
Operating Temperature Range	Top	Absolute Max	-20	-	+70	°C
Storage Temperature Range	Tst	Absolute Max	-30	-	+80	°C
Supply Voltage	VDD		2.8	-	3.3	V
Supply Current – Operating	IDD	Ta=25°C, VDD=2.8V	-	6.0	-	mA
Supply Current – Hibernate	IDD	Ta=25°C, VDD=2.8V	-	0.03	-	mA
"H" Level input	Vih		0.7*VDD	-	VDD	V
"L" Level input	Vil		VSS	-	0.3*VDD	V
"H" Level output	Voh		0.7*VDD	-	VDD	V
"L" Level output	Vol		VSS	-	0.3*VDD	V

Optical Characteristics:

Item	Symbol	Condition	Min.	Typ.	Max.	Unit
Viewing Angle – Top		Cr ≥10	60	75	-	°
Viewing Angle – Bottom			50	65	-	°
Viewing Angle – Left			60	75	-	°
Viewing Angle – Right			60	75	-	°
Contrast Ratio	Cr		500	600	-	
Luminance	YL		400	450	-	cd/m ²
Response Time	Tr+Tf	-	-	20	30	ms

Capacitive Touch Panel Material Characteristics:

Property	Requirement	Unit
IC	FT5306DE3	
Glass thickness	0.7	mm
Top film thickness	0.125	mm
Surface Hardness	6(750)	H(g)
Light transmission	82%	-
Operating Humidity	45~85	RH
Storage Humidity	5~95	RH

Timing Characteristics

Parameter	Symbol	Spec.			Unit
		Min.	Typ.	Max.	
HS setup time	T_{hst}	8	-	-	ns
HS hold time	T_{hhd}	8	-	-	ns
VS setup time	T_{vst}	8	-	-	ns
VS hold time	T_{vhd}	8	-	-	ns
Data setup time	T_{dsu}	8	-	-	ns
Data hold time	T_{dhd}	8	-	-	ns
DE setup time	T_{esu}	8	-	-	ns
DE hold time	T_{ehd}	8	-	-	ns
VDD Power On Slew rate	T_{POR}	-	-	20	ms
RSTB pulse width	T_{Rst}	10	-	-	us
CLKIN cycle time	T_{cph}	20	-	-	ns
CLKIN pulse duty	T_{cwh}	40	50	60	%
Output stable time	T_{sst}	-	-	6	us

Horizontal timing

Parameter	Symbol	Spec.			Unit
		Min.	Typ.	Max.	
Horizontal Display Area	thd		800		DCLK
DCLK frequency	fclk	-	30	50	MHz
One Horizontal Line	th	889	928	1143	DCLK
HS pulse width	thpw	1	48	255	DCLK
HS Back Porch (Blanking)	thb		88		DCLK
HS Front Porch	thfp	1	40	255	DCLK
DE mode Blanking	th-thd	85	128	512	DCLK

Vertical timing

Parameter	Symbol	Spec.			Unit
		Min.	Typ.	Max.	
Vertical Display Area	tvd		480		T_H
VS period time	tv	513	525	767	T_H
VS pulse width	tvpw	3	3	255	T_H
VS Back Porch (Blanking)	tvb		32		T_H
VS Front Porch	tvfp	1	13	255	T_H
DE mode Blanking	tv-tvd	4	45	255	T_H

Horizontal Timing

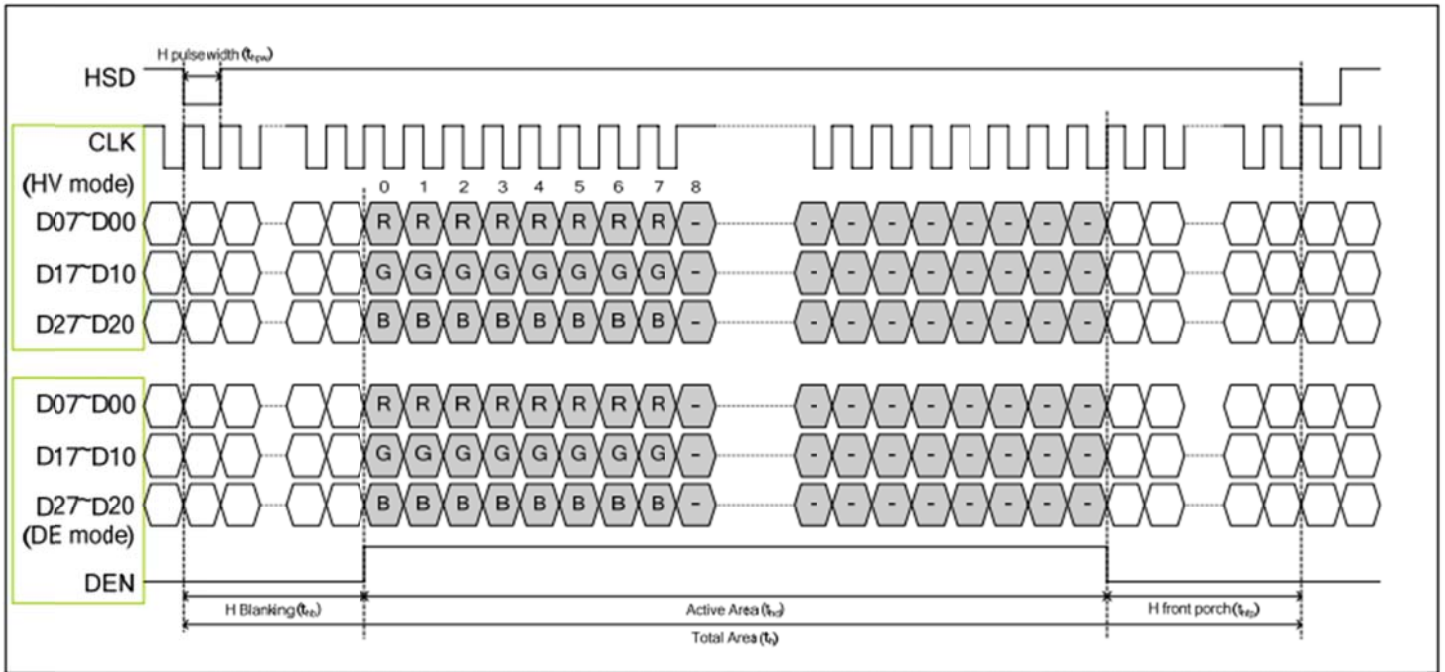

Vertical Timing

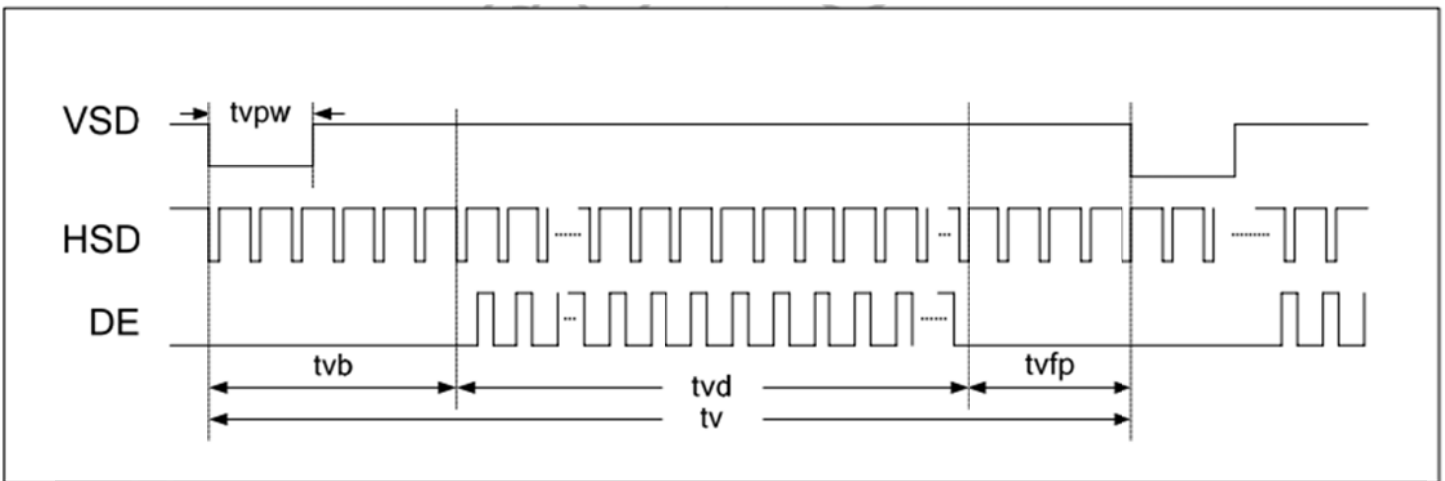

Parallel 24-bit RGB mode

Parameter	Symbol	Min.	Typ.	Max.	Unit	Conditions
CLKIN Frequency	Fclk	-	40	50	MHz	VDD=3.0V~3.6V
CLKIN Cycle Time	Tclk	20	25	-	ns	-
CLKIN Pulse Duty	Tcwh	40	50	60	%	Tclk
Time from HSD to Source Output	Thso		64		CLKIN	-
Time from HSD to LD	Thld		64		CLKIN	-
Time from HSD to STV	Thstv		2		CLKIN	-
Time from HSD to CKV	Thckv		20		CLKIN	-
Time from HSD to OEV	Thoev		4		CLKIN	-
LD Pulse Width	Twld		10		CLKIN	-
CKV Pulse Width	Twckv		66		CLKIN	-
OEV Pulse Width	Twoev		74		CLKIN	-

Input Clock and Data Timing

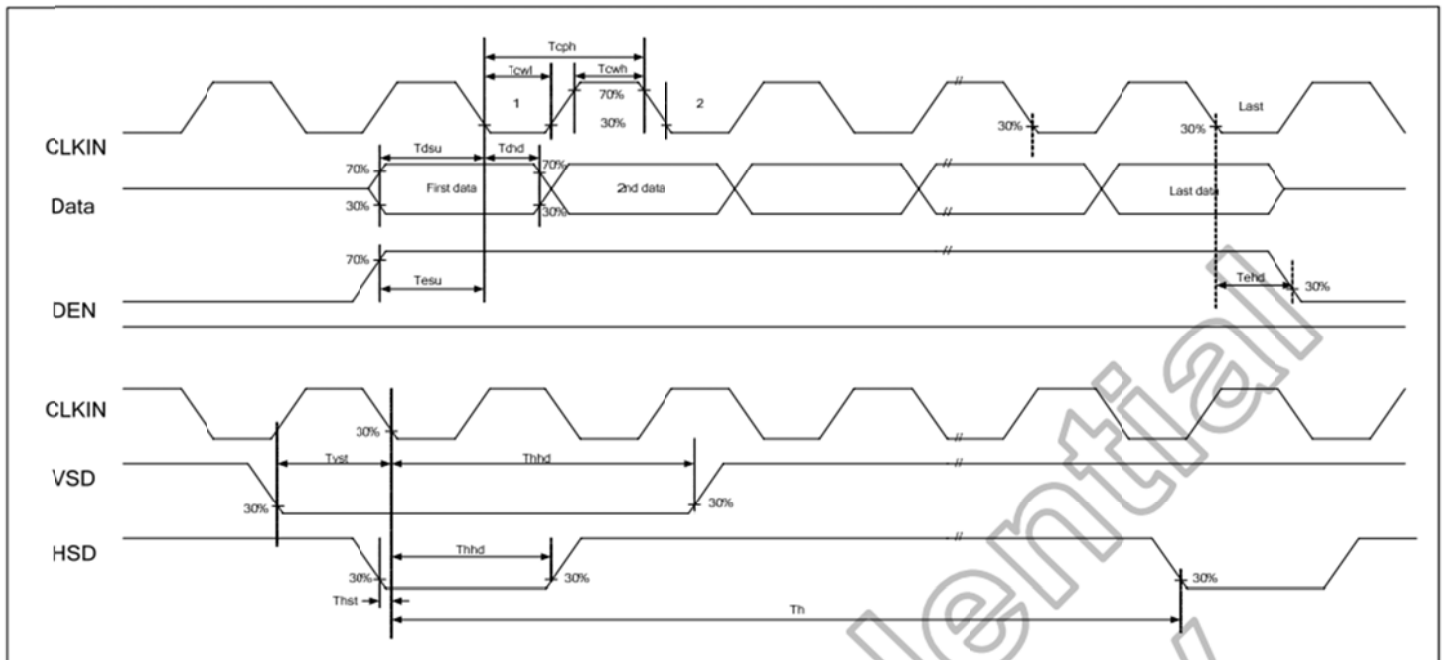

Source Output Timing

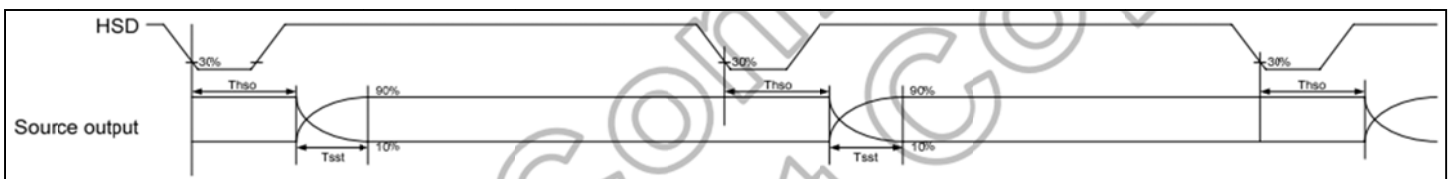

Vertical Timing HV (Cascade)

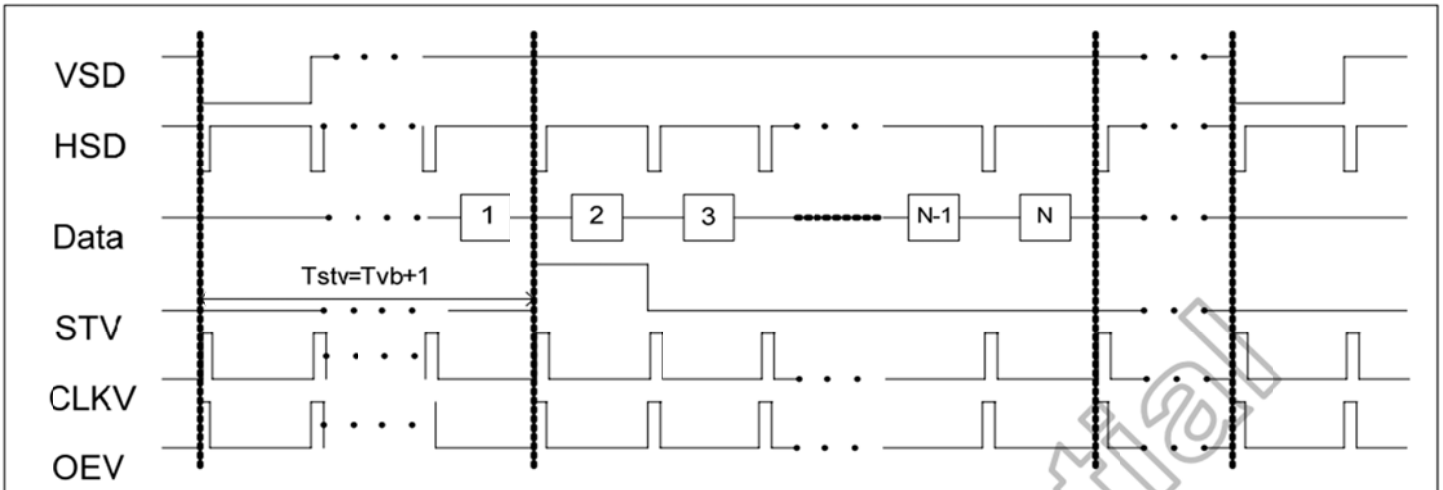

Vertical Timing DE (Cascade)

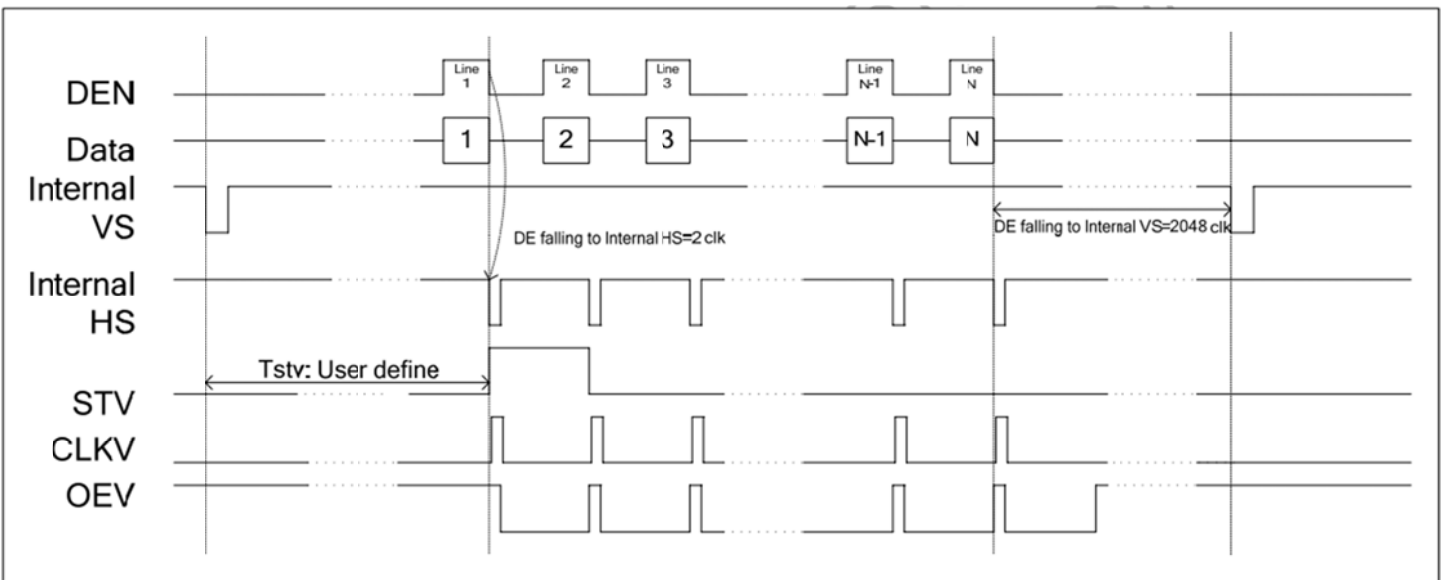

Gate Output Timing

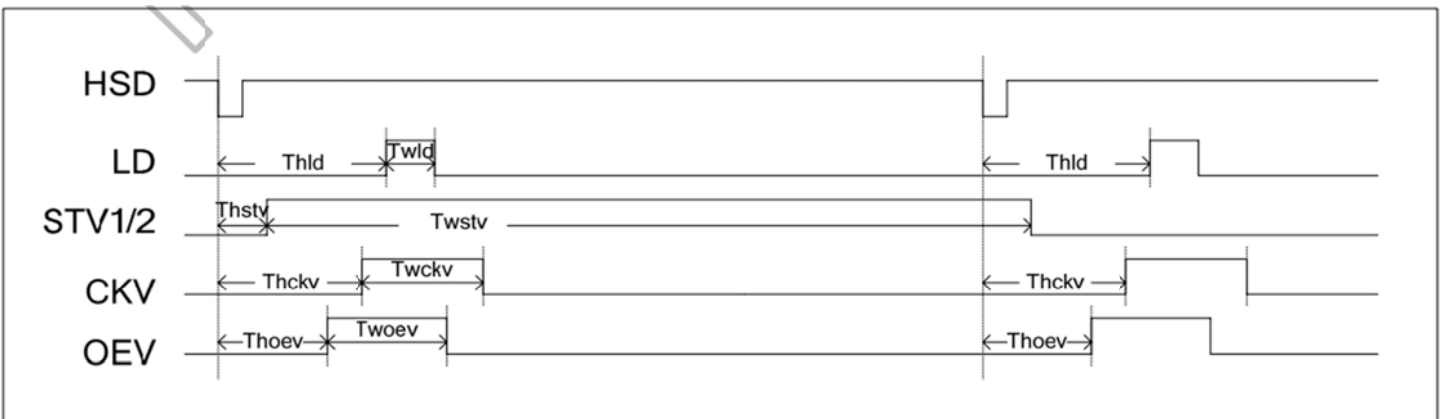

Vertical Timing HV (Dual Gate)

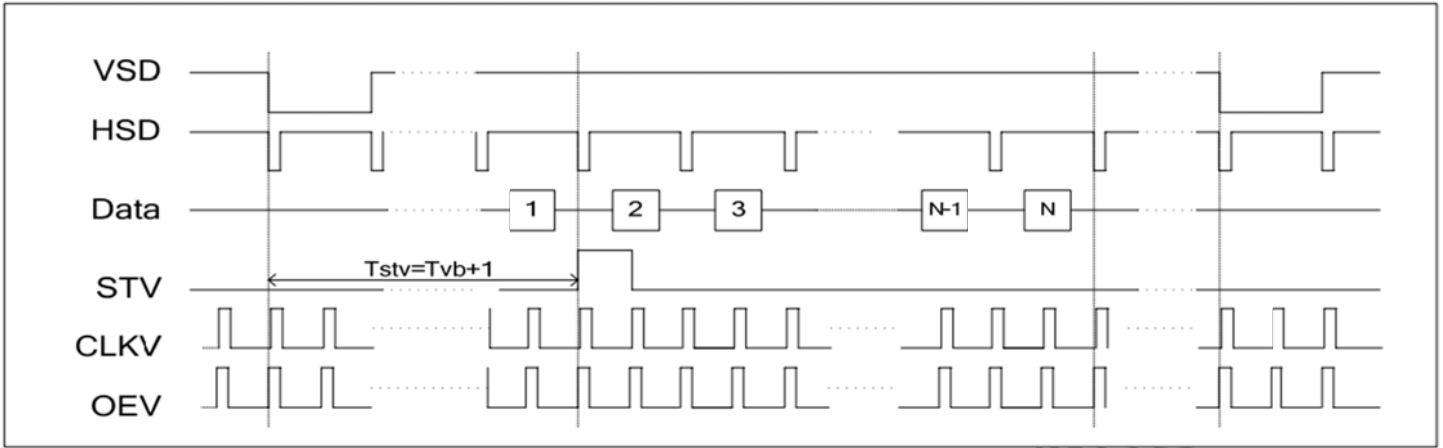

Vertical Timing DE (Dual Gate)

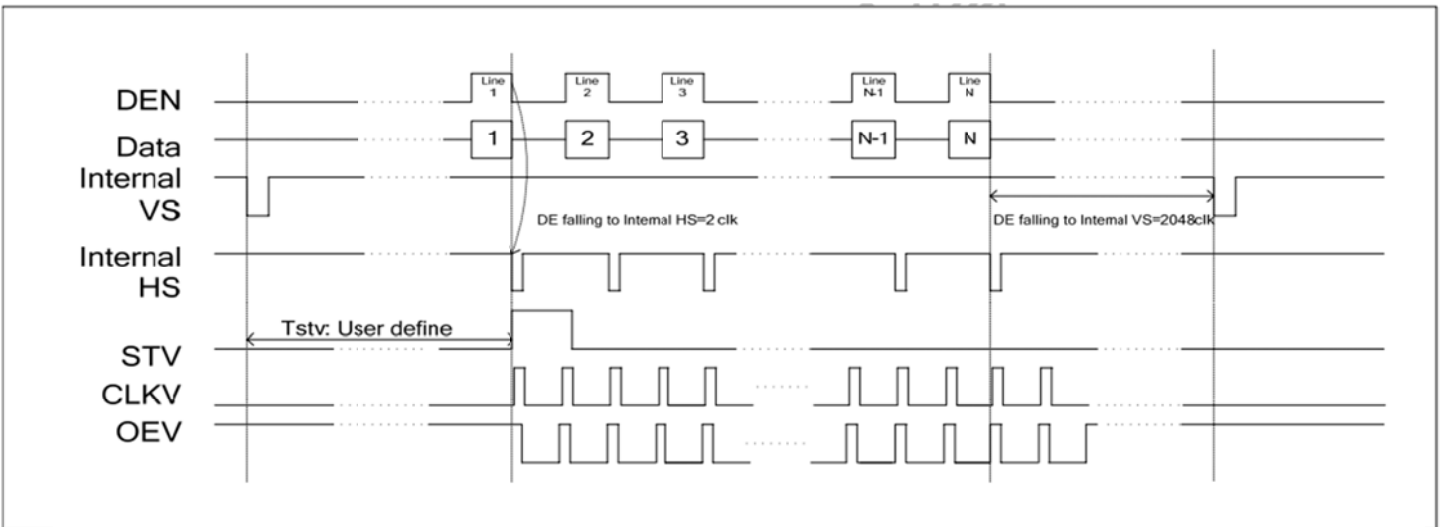

Gate Output Timing (Dual Gate)

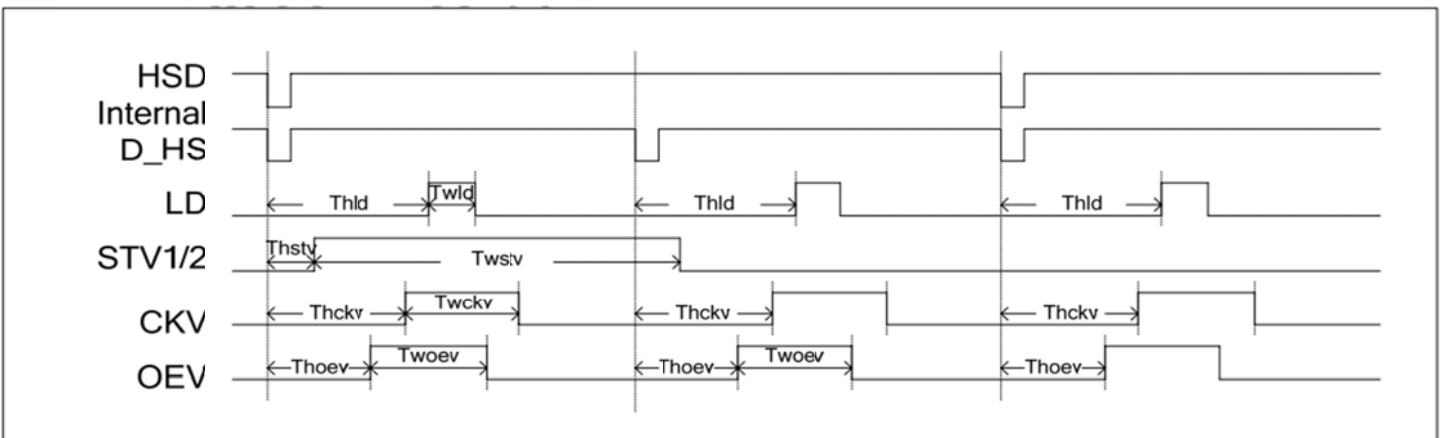

Power ON/OFF Sequence

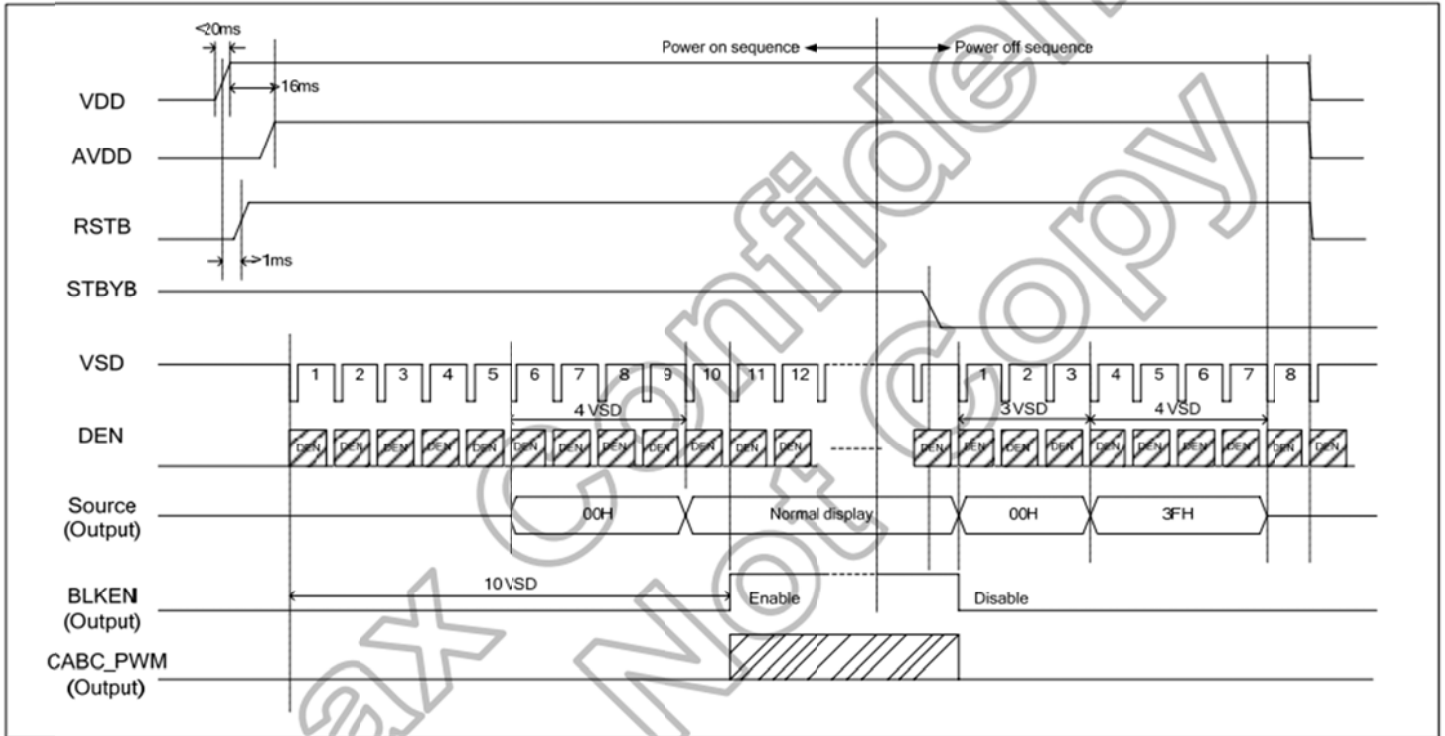

Enter/Exit Standby Mode Sequence

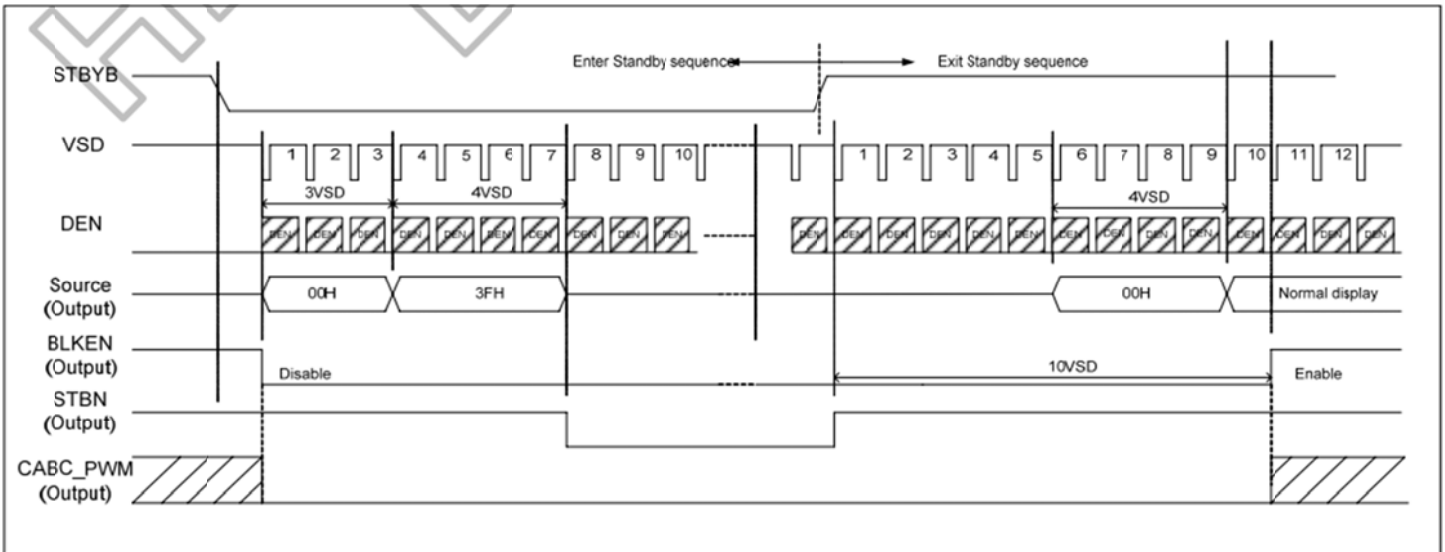

Capacitive Touch Panel Registers

Address	Name	B7	B6	B5	B4	B3	B2	B1	B0	Access	
00h	DEVICE_MODE	Device Mode [2..0]									R/W
01h	GEST_ID	Gesture ID [7..0]									R
02h	TD_STATUS							Touch Points [3..0]			R
03h	TOUCH1_XH	Event Flag			1st Touch X Position MSB [11..8]					R	
04h	TOUCH1_XL	1st Touch X Position LSB [7..0]									R
05h	TOUCH1_YH	Touch ID [3..0]			1st Touch Y Position MSB [11..8]					R	
06h	TOUCH1_YL	1st Touch Y Position LSB [7..0]									R
07h										R	
08h										R	
09h	TOUCH2_XH	Event Flag			2nd Touch X Position MSB [11..8]					R	
0Ah	TOUCH2_XL	2nd Touch X Position LSB [7..0]									R
0Bh	TOUCH2_YH	Touch ID [3..0]			2nd Touch Y Position MSB [11..8]					R	
0Ch	TOUCH2_YL	2nd Touch Y Position LSB [7..0]									R
0Dh										R	
0Eh										R	
0Fh	TOUCH3_XH	Event Flag			3rd Touch X Position MSB [11..8]					R	
10h	TOUCH3_XL	3rd Touch X Position LSB [7..0]									R
11h	TOUCH3_YH	Touch ID [3..0]			3rd Touch Y Position MSB [11..8]					R	
12h	TOUCH3_YL	3rd Touch Y Position LSB [7..0]									R
13h										R	
14h										R	
15h	TOUCH4_XH	Event Flag			4th Touch X Position MSB [11..8]					R	
16h	TOUCH4_XL	4th Touch X Position LSB [7..0]									R
17h	TOUCH4_YH	Touch ID [3..0]			4th Touch Y Position MSB [11..8]					R	
18h	TOUCH4_YL	4th Touch Y Position LSB [7..0]									R
19h										R	
1Ah										R	
1Bh	TOUCH5_XH	Event Flag			5th Touch X Position MSB [11..8]					R	
1Ch	TOUCH5_XL	5th Touch X Position LSB [7..0]									R
1Dh	TOUCH5_YH	Touch ID [3..0]			5th Touch Y Position MSB [11..8]					R	
1Eh	TOUCH5_YL	5th Touch Y Position LSB [7..0]									R
1Fh										R	

Address	Name	B7	B6	B5	B4	B3	B2	B1	B0	Access	
80h	ID_G_THGROUP	valid touching detect threshold								R/W	
81h	ID_G_THPEAK	valid touching peak detect threshold								R/W	
82h	ID_G_THCAL	the threshold when calculating the focus of touching								R/W	
83h	ID_G_THWATER	the threshold when there is surface water								R/W	
84h	ID_G_TEMP	the threshold of temperature compensation								R/W	
85h	ID_G_THDIFF	the threshold whether the coordinate is different from original								R/W	
86h	ID_G_CTRL						Power Control Mode [1..0]				R/W
87h	ID_G_TIME_ENTER_MONITOR	the timer for entering monitor status								R/W	
88h	ID_G_PERIODACTIVE						Period Active [3..0]				R/W
89h	ID_G_PERIODMONITOR	the timer of entering idle when in monitor status								R/W	
A0h	ID_G_AUTO_CLB_MODE	auto calibration mode								R/W	
A1h	ID_G_LIB_VERSION_H	Firmware Library Version H byte								R	
A2h	ID_G_LIB_VERSION_L	Firmware Library Version L byte								R	
A3h	ID_G_CIPHER	Chip vendor ID								R	
A4h	ID_G_MODE	the interrupt status to host								R	
A5h	ID_G_PMODE	Power Consume Mode									
A6h	ID_G_FIRMID	Firmware ID								R	
A7h	ID_G_STATE	Running State									
A8h	ID_G_FT5201ID	CTPM Vendor ID								R	
A9h	ID_G_ERR	Error Code								R	
AAh	ID_G_CLB	Configure TP module during calibration in Test Mode								R/W	
FEh	LOG_MSG_CNT	The log MSG count								R	
FFh	LOG_CUR_CHA	Current character of log message								R	

NOTE: Registers 80h – AFh have been configured for optimum settings and do not need to be modified.

Register No	Register Name	Bits	Value	Description
00h	Device Mode	[2:0]	000b	Normal Operating Mode
			100b	Test Mode - read raw data (reserved)
			001b	System Information Mode (reserved)
01h	Gesture ID	[7:0]	48h	Zoom In
			49h	Zoom Out
			00h	No Gesture
02h	Touch Points	[3:0]	000b	0 touch points detected
			001b	1 touch point detected
			010b	2 touch points detected
			011b	3 touch points detected
			100b	4 touch points detected
			101b	5 touch points detected
03h	Touch 1 Event Flag	[7:6]	00b	Put Down
			01b	Put Up
			10b	Contact
			11b	Reserved
03h	TOUCH1_XH	[3:0]	0h - 3h	Upper 4 bits of X touch coordinate
04h	TOUCH1_XL	[7:0]	00h - FFh	Lower 8 bits of X touch coordinate
05h	TOUCH1_YH	[3:0]	0h - 1h	Upper 4 bits of Y touch coordinate
06h	TOUCH1_YL	[7:0]	00h - FFh	Lower 8 bits of Y touch coordinate
09h	Touch 2 Event Flag	[7:6]	00b	Put Down
			01b	Put Up
			10b	Contact
			11b	Reserved
09h	TOUCH2_XH	[3:0]	0h - 3h	Upper 4 bits of X touch coordinate
0Ah	TOUCH2_XL	[7:0]	00h - FFh	Lower 8 bits of X touch coordinate
0Bh	TOUCH2_YH	[3:0]	0h - 1h	Upper 4 bits of Y touch coordinate
0Ch	TOUCH2_YL	[7:0]	00h - FFh	Lower 8 bits of Y touch coordinate
0Fh	Touch 3 Event Flag	[7:6]	00b	Put Down
			01b	Put Up
			10b	Contact
			11b	Reserved
0Fh	TOUCH3_XH	[3:0]	0h - 3h	Upper 4 bits of X touch coordinate
10h	TOUCH3_XL	[7:0]	00h - FFh	Lower 8 bits of X touch coordinate
11h	TOUCH3_YH	[3:0]	0h - 1h	Upper 4 bits of Y touch coordinate
12h	TOUCH3_YL	[7:0]	00h - FFh	Lower 8 bits of Y touch coordinate
15h	Touch 4 Event Flag	[7:6]	00b	Put Down
			01b	Put Up
			10b	Contact
			11b	Reserved
15h	TOUCH4_XH	[3:0]	0h - 3h	Upper 4 bits of X touch coordinate
16h	TOUCH4_XL	[7:0]	00h - FFh	Lower 8 bits of X touch coordinate
17h	TOUCH4_YH	[3:0]	0h - 1h	Upper 4 bits of Y touch coordinate
18h	TOUCH4_YL	[7:0]	00h - FFh	Lower 8 bits of Y touch coordinate

Register No	Register Name	Bits	Value	Description
1Bh	Touch 5 Event Flag	[7:6]	00b 01b 10b 11b	Put Down Put Up Contact Reserved
1Bh	TOUCH5_XH	[3:0]	0h - 3h	Upper 4 bits of X touch coordinate
1Ch	TOUCH5_XL	[7:0]	00h - FFh	Lower 8 bits of X touch coordinate
1Dh	TOUCH5_YH	[3:0]	0h - 1h	Upper 4 bits of Y touch coordinate
1Eh	TOUCH5_YL	[7:0]	00h - FFh	Lower 8 bits of Y touch coordinate
80h	ID_G_THGROUP	[7:0]	00h - FFh	Valid touching detect threshold Actual value will be 4 times register's value Default : 1Eh
81h	ID_G_THPEAK	[7:0]	00h - FFh	valid touching peak detect threshold Default : 3Ch
82h	ID_G_THCAL	[7:0]	00h - FFh	Touch focus threshold Default : 14h
83h	ID_G_THWATER	[7:0]	00h - FFh	threshold when there is surface water Default : D0h
84h	ID_G_THTEMP	[7:0]	00h - FFh	threshold of temperature compensation Default : 66h
85h	ID_G_THDIFF	[7:0]	00h - FFh	Touch difference threshold Actual value is 32 times the register's value Default : A0h
86h	ID_G_CTRL	[1:0]	00h 01h	Power Control Mode: Not Auto Jump Power Control Mode: Auto Jump
87h	ID_G_TIME_ENTER_MONITOR	[7:0]	00h-FFh	Delay to enter 'Monitor' status (s) Default : C8h
88h	ID_G_PERIODACTIVE	[3:0]	3h-Eh	Period of 'Active' status (ms) Default : 6h
89h	ID_G_PERIODMONITOR	[7:0]	1Eh-FFh	Timer to enter 'idle' when in 'Monitor' (ms) Default : 28h
A0h	ID_G_AUTO_CLB_MODE	[7:0]	00h FFh	Auto calibration mode: Enable auto calibration Auto calibration mode: Disable auto calibration
A1h	ID_G_LIB_VERSION_H	[7:0]	30h	Firmware Library Version H byte
A2h	ID_G_LIB_VERSION_L	[7:0]	01h	Firmware Library Version L byte
A3h	ID_G_CIPHER	[7:0]	55h	Chip vendor ID
A4h	ID_G_MODE	[0:0]	00h 01h	Interrupt status: Enable interrupt to host Interrupt status: Disable interrupt to host
A5h	ID_G_PMODE	[1:0]	00h 01h 03h	'Active' Mode 'Monitor' Mode 'Hibernate' Mode
A6h	ID_G_FIRMID	[7:0]	05h	Firmware ID
A7h	ID_G_STATE	[7:0]	00h 01h 02h 03h 04h	Running State: Configure Running State: Work Running State: Calibration Running State: Factory Running State: Auto-calibration
A8h	ID_G_FT5201ID	[7:0]	79h	CTPM Vendor's Chip ID
A9h	ID_G_ERR	[7:0]	00h 03h 05h 1Ah	Error Code: OK Error Code: Chip register writing inconsistent with reading Error Code: Chip start fail Error Code: Calibration match fail

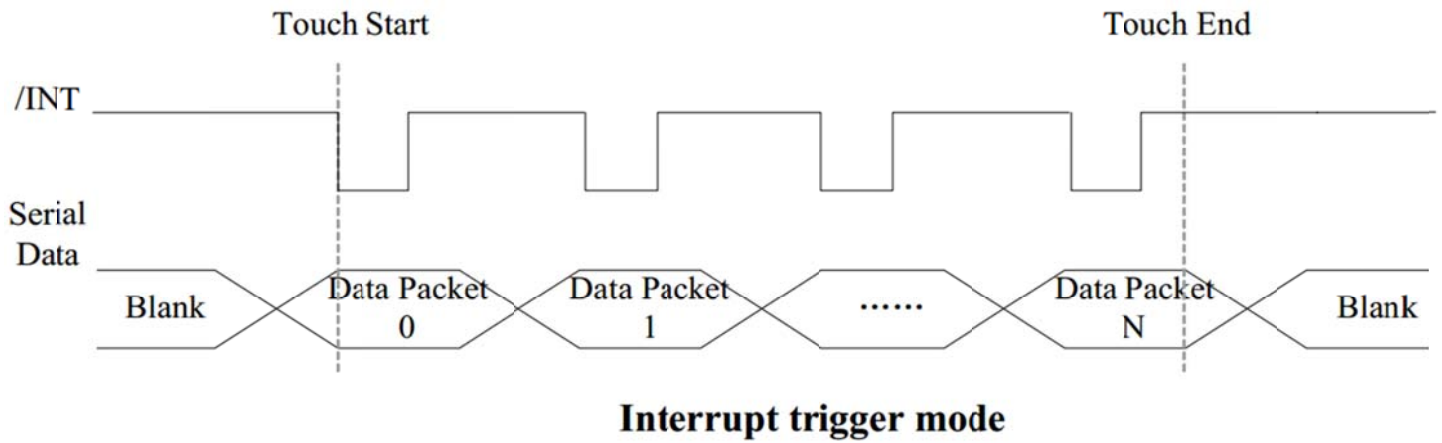

Sample code to read touch data:

```

i2c_start();
i2c_tx(0x70);           //Slave Address (Write)
i2c_tx(0x00);           //Start reading address
i2c_stop();

i2c_start();
i2c_tx(0x71);           //Slave Address (Read)
for(i=0x00;i<0x1F;i++)
{touchdata_buffer[i] = i2c_rx(1);}
i2c_stop();

```

Sample code to overwrite default register values:

```

i2c_start();
i2c_tx(0x70);           //Slave Address (Write)
i2c_tx(0xA4);           //ID_G_Mode
i2c_tx(0x01);           //Disable interrupt status to host
i2c_stop();

```

Quality Information

Test Item	Content of Test	Test Condition	Note
High Temperature storage	Endurance test applying the high storage temperature for a long time.	+80°C , 200hrs	2
Low Temperature storage	Endurance test applying the low storage temperature for a long time.	-30°C , 200hrs	1,2
High Temperature Operation	Endurance test applying the electric stress (voltage & current) and the high thermal stress for a long time.	+70°C 200hrs	2
Low Temperature Operation	Endurance test applying the electric stress (voltage & current) and the low thermal stress for a long time.	-20°C , 200hrs	1,2
High Temperature / Humidity Operation	Endurance test applying the electric stress (voltage & current) and the high thermal with high humidity stress for a long time.	+60°C , 90% RH , 96hrs	1,2
Thermal Shock resistance	Endurance test applying the electric stress (voltage & current) during a cycle of low and high thermal stress.	-20°C,30min -> 25°C,5min ->70°C,30min = 1 cycle 10 cycles	
Vibration test	Endurance test applying vibration to simulate transportation and use.	10-55Hz , 15mm amplitude. 60 sec in each of 3 directions X,Y,Z For 15 minutes	3
Static electricity test	Endurance test applying electric static discharge.	VS=800V, RS=1.5kΩ, CS=100pF One time	

Note 1: No condensation to be observed.

Note 2: Conducted after 4 hours of storage at 25°C, 0%RH.

Note 3: Test performed on product itself, not inside a container.

Precautions for using LCDs/LCMs

See Precautions at www.newhavendisplay.com/specs/precautions.pdf

Warranty Information and Terms & Conditions

http://www.newhavendisplay.com/index.php?main_page=terms